



VM 1700

LIST OF THE EXPLODED VIEWS



SHELL ASSY

COOLING SYSTEM

HYDRAULIC CIRCUIT

SPRAYER PUMP

ELECTRIC PARTS



VM 1700

SHELL ASSY

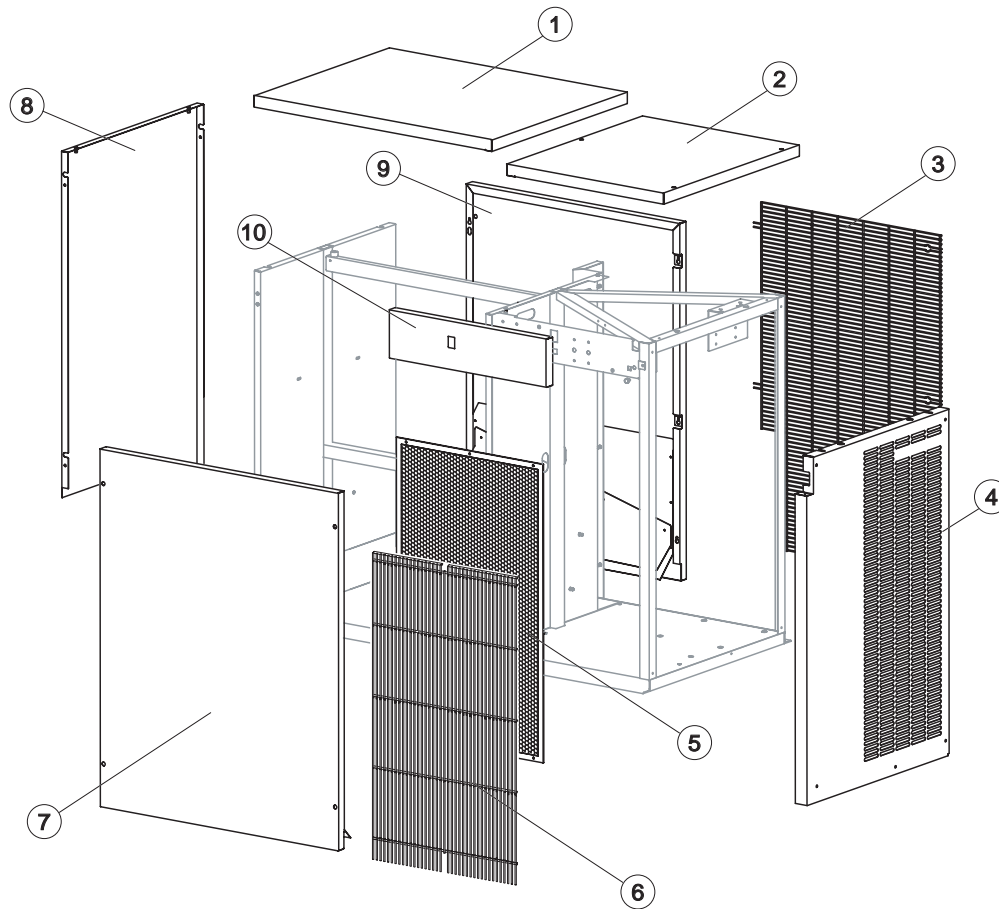

Ref.	Spare Description	Code
1	Top-Evaporator Side	C22371
2	Top-Condenser Side	22370
3	Rear Grid	12077
4	Right Side Panel	22364
5*	Filter	18192
6	Front Grid	12079
7	Front Panel Assembly	C22368
8	Left Side Panel	22366
9	Rear Panel Assembly	C22367
10	Electrical Box Cover Panel	22623

Rev. 7. - 12/03/2019

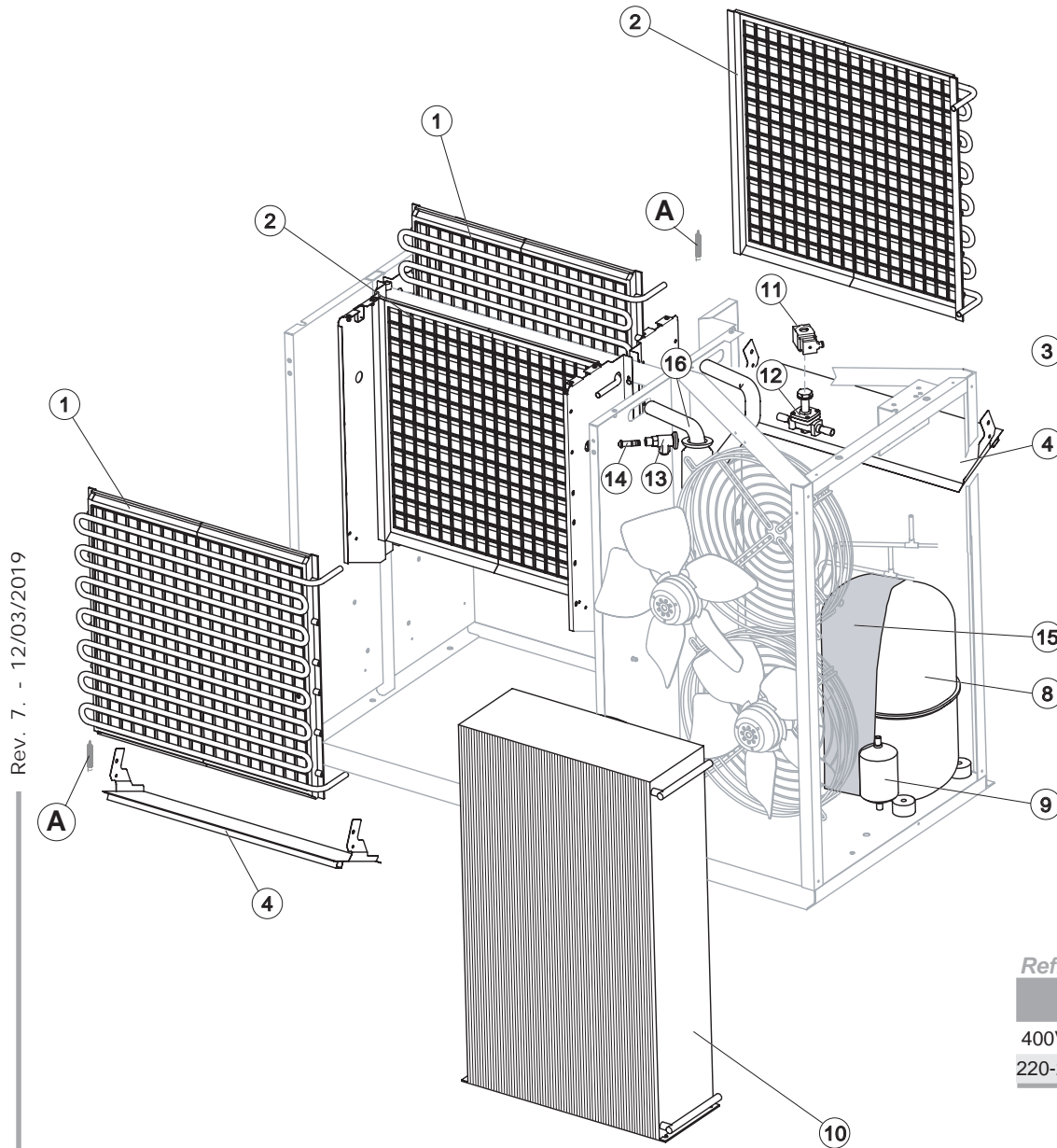

Rev. 7. - 12/03/2019

Ref.	Spare Description	Code
1	Evaporator (Front)	D10504
2	Evaporator (Back)	D10505
4	Horizontally Hinged Panel	22385
8	Compressor	See Table
9*	Solid Filter	14255
10	Air Condenser	20830
11*	Hot Gas Valve Coil	231294
12*	Hot Gas Valve Body	20832
13	Expansion Valve	20826
14	Orifice	Current Version 20946
14	Orifice	Till s/n. 471749 20794
15	Compressor Insulation	18254
16	Suctin Line	for the spare parts code give us the s/n.

! Eliminated the Spring (horizontally hinged panel) ref. A, suggested removal even from the models where they are present.

Ref. 8 - Compressor

Voltage	Code	Code	Code
	Current Version	from s/n. 681899 till ...	till s/n. 681898
400V 3~ 50-60Hz	231367	R231100 till s/n. 962853	23817
220-230V 3~ 60Hz	231101	231101	23824

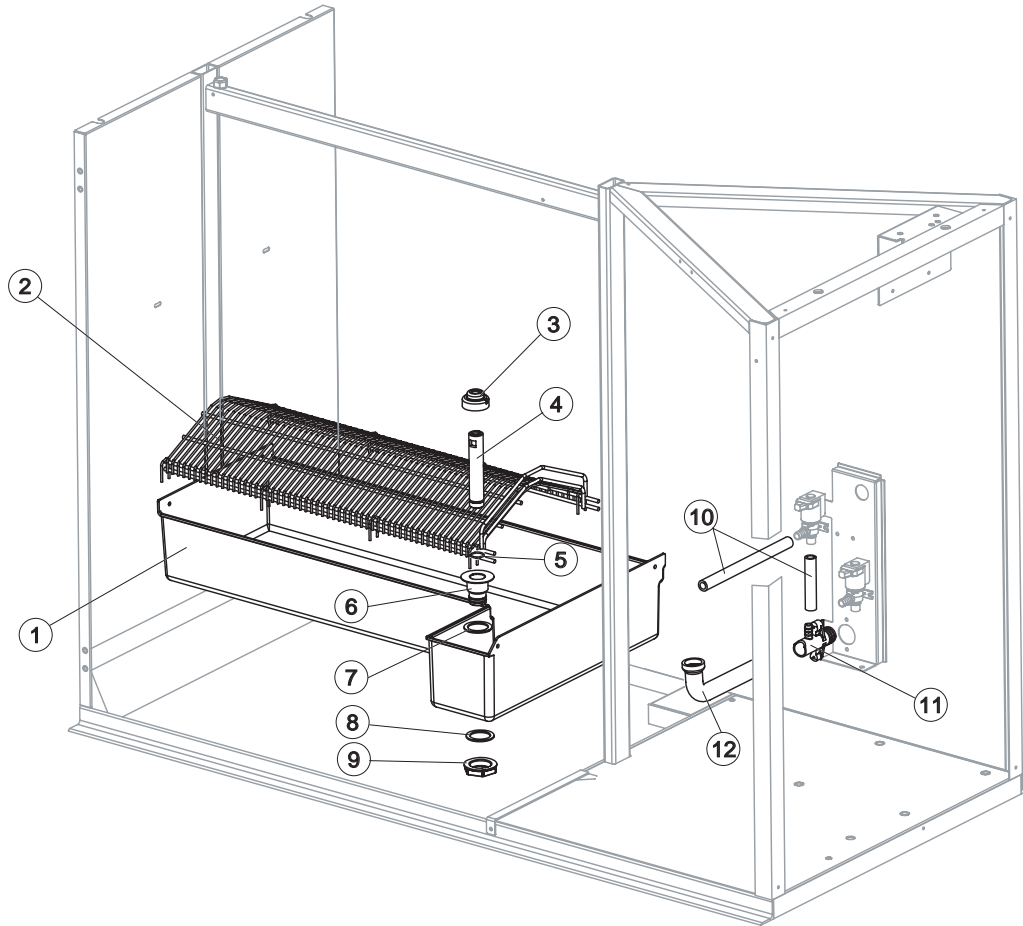

Rev. 7. - 12/03/2019

Ref.	Spare Description	Code
1	Water Basin	10501
2	Ice Cubes Slide	D12078
3*	Overflow Cap	10305
4*	Overflow Pipe	10399
5*	OR Gasket for Overflow Pipe	20233
6	Overflow Pipe Nipple	10472
7	Silicone Gasket	13219
8	Semirigid Polyethylene Gasket	13007
9	Bin Discharge Nut	10096
10	Connection Pipe	13102
11	Discharge Nipple	10431
12	Basin Discharge Pipe	13174

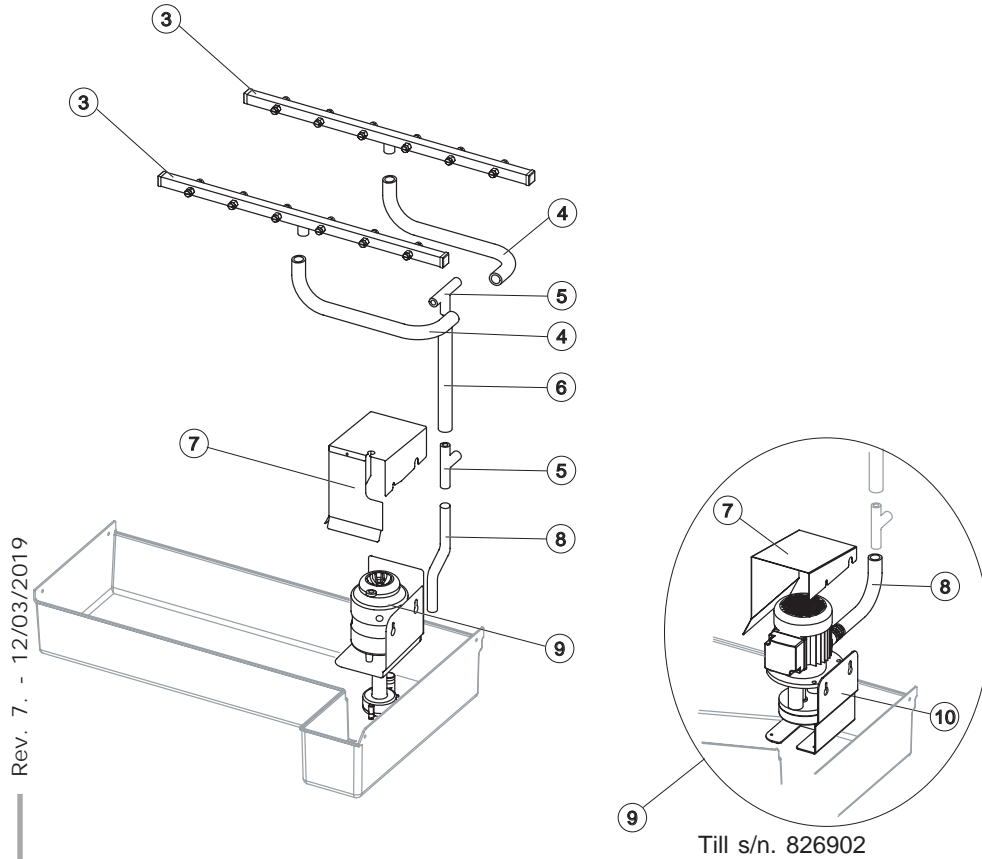

Ref.	Spare Description	Code
3*	Sprayer Bar Assembly	C20617
4	Sprayer Bar Connection Pipe	13134
5	Plastic "T" Joint - \varnothing 20	10082
6	Connection Pipe	13111
7	Pump Protection Panel	Current Version 221704
7	Pump Protection Panel	Till s/n. 826902 22377
8	Connection Pipe	Current Version C13113
8	Connection Pipe	Till s/n. 826902 13005
9*	Pump	See Table
10	Pump Motor Support	Till s/n. 826902 22383

Ref. 9* - Pump

Voltage	Current Version	Till s/n. 826902
50Hz	C231218	K231218
60Hz	C231218	K231218

Rev. 7. - 12/03/2019

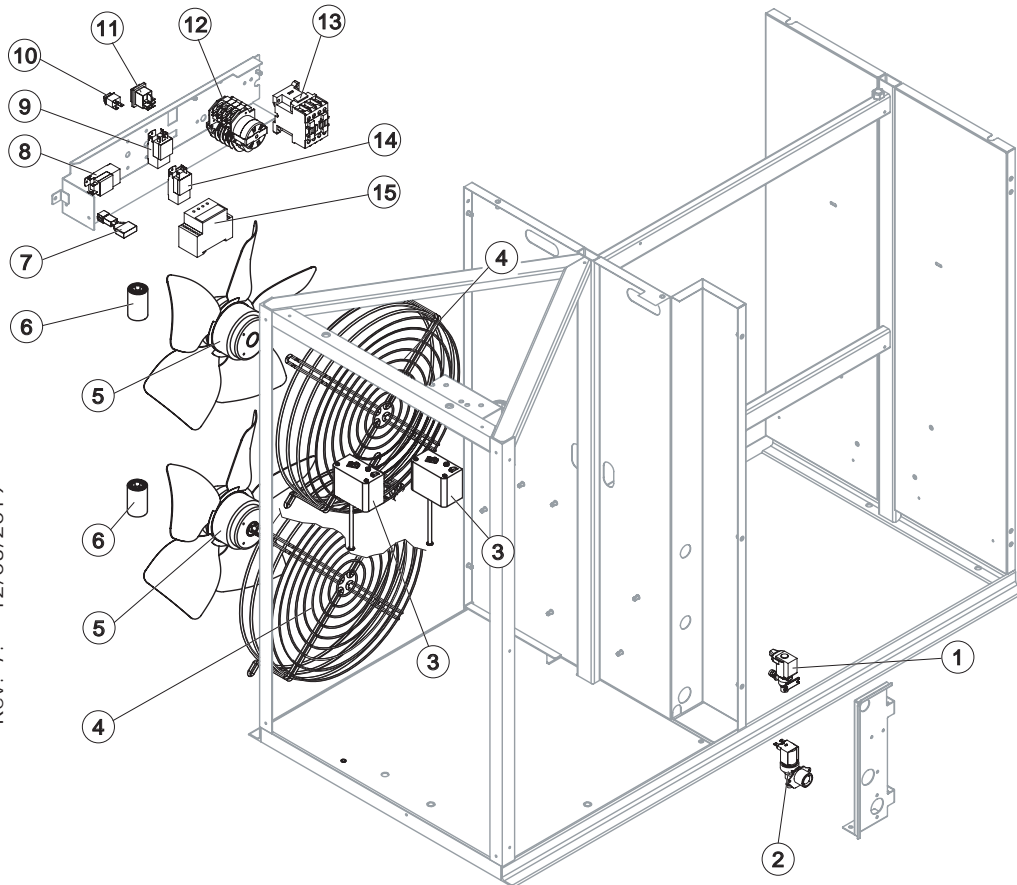

Rev. 7. - 12/03/2019

Ref.	Spare Description	Code
1*	Water Outlet Valve	23537
2*	1 Way-Water Inlet Valve	23819
3	Safety Pressure Switch	23729
4	Fan Motor Grid	12053
5*	Fan Motor	23468
6*	5µF Capacitor	23469
7	Anti Radio Interference Filter	Only 400-415V 3N~ 50-60Hz C23459
8*	Condenser Pressure Switch	23175
9*	Evaporator Thermostat	Current Version for 400-415V 3N~ 50-60Hz R23591
9*	Evaporator Thermostat	For 400-415V 3N~ 50-60Hz till s/n. 962853 R23597
9*	Evaporator Thermostat	For 220-230V 3~ 60Hz R23597
10	"Cleaning" Switch	23619
11*	Green Light Switch (On-Off)	23327
12*	Timer	See Table
13*	Contactor	23398
14*	Bin Thermostat	R23005
15	Voltage Control Relay	See Table

Ref. 12* - Timer

Voltage	Code
400-415V 3N~ 50-60Hz	23635
220-230V 3~ 60Hz	23632

Ref. 15 - Voltage control relay

Voltage	Code
400V 3~ 50-60Hz	23903
220-230V 3~ 60Hz	23904